

WATERPROOF SPC Installation & Maintenance

INSTALLATION & MAINTENANCE

BEFORE INSTALLING

INSTALLATION

FINISHING

REPLACEMENT

MAINTENANCE

PLEASE READ BEFORE INSTALLATION!

FOR BEST VISUAL REPRESENTATION OF YOUR FLOOR

This flooring replicates the look of a natural product which has natural variations in color and texture. For best visual effect, shuffle planks from several cartons and do not install similar boards next to one another.

SUBFLOOR PREPARATION

Subfloor should be dry and level to 3/16" per 10 ft. radius for best installation results.

Vinyl flooring should only be used indoors.

FLOORING MATERIAL SHOULD BE INSPECTED PRIOR TO INSTALLATION

Responsibility for the suitability of Manufacturer flooring and accompanying products for each individual installation cannot be assumed by Manufacturer, since Manufacturer has no control over the installer's proper application. Should an individual plank or tile be doubtful as to appearance or dimension the installer should not use this piece. Once a plank is installed it is deemed acceptable by a Homeowner/Installer.

NOTE: Manufacturer flooring with attached underlayment CANNOT be installed with a glue-down method.

READ BEFORE INSTALLING

While flooring is waterproof, it's not a moisture barrier. It's still a good idea to make sure concrete is cured and tested for moisture and that a moisture barrier is installed in the crawl space and even under a floor over a concrete sub-floor. Please refer below for further guidance.

Please check for defects, squeaky noises, sub-floor issue or finish issues by installing 100 sq. ft. of flooring.

Moisture won't damage flooring, but it can get in the walls and structure of the home. A couple of extra dollars and a few minutes is a small investment for the added protection and peace of mind. Because houses and buildings, as well as adjacent hardwood or laminate floors, expand and contract, Manufacturer recommends leaving a 1/4" expansion gap between the perimeter walls and any adjacent hardwood floor. Do not install floors where it will be exposed to temperatures greater than 140° F. Use good common-sense installation practices, and you'll have a successful installation that results in a beautiful floor.

Check that all BATCH NUMBERS AND ITEM NUMBERS are the same and that you have purchased sufficient packs to complete the job.

KEYS TO SUCCESSFUL LOCKING INSTALLATION

All tiles and planks should be checked before and during installation for faults which

INSTALLATION & MAINTENANCE

BEFORE INSTALLING

INSTALLATION

FINISHING

REPLACEMENT

MAINTENANCE

are clearly visible; this will reduce problems when assembling and identify any color differences. The inspection should be performed in daylight, or under good artificial lighting, in the room in which the Products are to be installed. If flooring is not acceptable, contact your supplier immediately and arrange for replacement. Manufacturer cannot accept responsibility for flooring installed with visible defects. Prior to installation of any flooring, the installer must ensure that the job-site and sub-floor meet the requirements of these instructions. Manufacturer is not responsible for flooring failure resulting from unsatisfactory job-site and/or sub-floor conditions.

Flooring should be one of the last items installed in any new construction or remodel project.

Crawl spaces must be a minimum of 18" (46 cm) from the ground to the underside of the joists. A ground cover of 6–20 mil black polyethylene film is essential as a vapor barrier with joints lapped 6" (15 cm) and sealed with moisture resistant tape. The crawl space should have perimeter venting equal to a minimum of 1.5% of the crawl space square footage. These vents should be properly located to foster cross ventilation. Local regulations prevail where necessary.

Room temperature and humidity of installation area should be consistent with normal, year-round living conditions for at least one week before installation of flooring. Maintaining an optimum room temperature of 70° F and a humidity range of 30-50% is recommended.

Most installations will need approximately a 10% cutting and waste allowance added to the square footage of the room.

Proper conditioning of the job site is necessary. Flooring planks should not be exposed to sudden changes in temperature. Store, transport and handle the flooring planks in a manner to prevent any distortions. Distortions will not disappear over time. Store cartons flat, never on edge. Insure that the flooring planks are lying flat at time of installation.

Installations of carpet, tiles, metal strips and other transition moldings should not push fully into the flooring and should allow for some slight movement wherever practical.

For rooms, wider or longer than 50', the use of T-moldings is required to account for the normal movement or seasonal expansion/contraction of the floor. If the homeowner does experience gapping then we would suggest the contractor tap the planks back together since they may come apart for longer run lengths.

Protect the floor from heavy-rolling loads, other trades, and movement of appliances by using sheets of plywood or similar.

SUITABLE SUBSTRATES

All substrates listed below must be properly prepared and meet certain requirements. There may be other exceptions and special conditions (as noted below) for these substrates to be suitable for the locking installation system.

- Concrete – dry and smooth on all grade levels
- Suspended wood sub-floors with approved wood underlayments – must have minimum of 18" well-ventilated crawl space underneath
- Suspended hardwood flooring that is fully adhered, smooth and square edge without texture
- Single-layer, fully-adhered, existing resilient floors – must not be foam-backed or cushion backed
- Ceramic tile, Terrazzo, Marble
- Polymeric Poured (seamless) Floors

INSTALLATION & MAINTENANCE

BEFORE INSTALLING

INSTALLATION

FINISHING

REPLACEMENT

MAINTENANCE

- Use Ply-Wood/OSB-3/4"
- Particleboard 40lb. density or wafer board

DO NOT INSTALL OVER

- Existing resilient tile floors that are below grade
- Existing cushion-backed vinyl flooring
- Carpet
- Hardwood flooring that has been installed directly over concrete
- On stairs or in rooms with sloping floors or floor drains

SUCCESSFUL WAYS TO AVOID MOVEMENT OR NOISE

Squeaking and clicking noises can be a result of many causes putting stress on the locking system;

- Locking system not engaged completely on both short and long joints. (To avoid this make sure to use a rubber mallet to engage each plank together and test each row).
- Do NOT use improper underlayment. (Please contact manufacturer to confirm underlayment).
- Joist/sub-floors moving which cause squeaky noises.
- Do NOT use any end joint that are broken (during transit or installation).
- Provide a minimum .25" on each wall space for expansion. (Lack of proper expansion space can cause peaking/tenting on the end joints).
- Confirming that floor is flat before installation. (Sub-floor deflection is not within manufacturer tolerance and the floor is not flat).
- Do NOT install floors in an extreme environment.

Sometimes, it is impossible to eliminate the noise completely. Minor squeaking or clicking noises are to be accepted as normal flooring phenomenon.

PRE-INSTALLATION SUBFLOOR REQUIREMENTS

All Sub-floors must be:

- Dry
- Structurally sound
- Clean: Thoroughly swept and free of all debris
- Level: Flat to 4.7mm (3/16") per 3.3 meters (10-foot) radius

Wood sub-floors must be dry and well secured. Nail or screw every 6" along joists to avoid squeaking. If not level, sand down high spots and fill low spots with a Portland Based leveling patch.

Concrete sub-floors must be fully cured, at least 60 days old, and should have minimum 6-mil poly-film between concrete and ground. Sub-floor should be flat and level within 3/16" per 10' radius. If necessary grind high spots down and level low spots with a Portland leveling compound.

Ceramic Tile, resilient tile and sheet vinyl must be well-bonded to sub-floor, in good condition, clean and level. Do not sand existing vinyl floors, as they may contain asbestos.

Resilient flooring should only be installed in temperature-controlled environments. It is necessary to maintain a constant temperature before, during and after the installation. Therefore, the permanent or temporary HVAC system must be in operation before the installation of resilient flooring. Portable heaters are not recommended as they may not heat the room and sub-floor sufficiently. Kerosene heaters should never be used.

INSTALLATION & MAINTENANCE

BEFORE INSTALLING

INSTALLATION

FINISHING

REPLACEMENT

MAINTENANCE

All substrates must be structurally sound, dry, clean, flat, and smooth with minimal deflection. Substrates must be free from excessive moisture or alkali. Remove dirt, paint, varnish, wax, oils, solvents, other foreign matter and contaminants.

High spots on the substrate should be leveled and low areas filled with appropriate underlayments.

Do not use products containing petroleum, solvents or citrus oils to prepare substrates as they can cause staining and expansion of the new flooring.

For renovation or remodel work, remove any existing adhesive residue so that 100% of the overall area of the original substrate is exposed.

Embossed existing resilient floors, ceramic tile floors, ceramic and marble grout joints, and irregularities in concrete should be filled.

Maintain temperatures between 55°F (13°C) and 85°F (29°C).

For concrete substrates, conduct moisture testing (moisture vapor emission rate {MVER}) not to exceed 5lbs and/or percent relative humidity 85% (in-situ probe). Bond tests must also be conducted for compatibility with the substrate.

Please refer to Sub-floors and Underlayments

- Radiant heated substrates must not exceed a maximum surface temperature of 81°F (27 °C).
- The sub-floor panels must have a smooth, sanded face and show no swelling of edges or surface due to exposure to weather conditions or construction traffic.
- There are numerous products available for use as floor fills, patches, self-leveling underlayments, and trowelable underlayments. They include proprietary blends of compounds such as Portland cement, calcium aluminates, and gypsum based products. These are recommended for smoothing rough or uneven sub-floors, enhancing acoustical and fire characteristics of structures or as substrates to receive floor covering for otherwise unsuitable sub-floor conditions.

INSTALLATION TOOLS

For all installation methods:

- Tape measure
- Tapping block (trimmed piece of flooring)
- Pencil
- Leveler
- Rubber Mallet
- 1/4" Spacers
- Pry bar or pull bar
- Chalk line
- Crosscut power saw

Acceptable sub-floor types:

- CDX Underlayment Grade Plywood (at least 1/2" thick)
- Underlayment grade particleboard
- OSB (at least 3/4" thick)
- Concrete slab
- Existing wood floor
- Ceramic tile, Resilient tile & sheet vinyl
- 3M Scotch-Blue™ 2080 Tape

INSTALLATION & MAINTENANCE

BEFORE INSTALLING

INSTALLATION

FINISHING

REPLACEMENT

MAINTENANCE

STARTING YOUR INSTALLATION

Work from several open boxes of flooring and “dry lay” the floor before permanently laying the floor. This will allow you to select the varying grains & colors and to arrange them in a harmonious pattern. Remember, it is the installer’s responsibility to determine the expectations of what the finished floor will look like with the end user first and then to cull out pieces that do not meet those expectations.

Begin installation next to an outside wall. This is usually the straightest and best reference for establishing a straight working line. Establish this line by measuring an equal distance from the wall at both ends and snapping a chalk line. The distance you measure from the wall should be the width of a plank. You may need to scribe cut the first row of planks to match the wall in order to make a straight working line if the wall is out of straight.

You may want to position a few rows before starting installation to confirm your layout decision and working line. When laying flooring, stagger end joints from row to row by at least 8”. When cutting the last plank in a row to fit, you can use the cut-off end to begin the next row. If cut-off end is 8” in length or less, discard it and instead cut a new plank at a random length and use it to start the next row. Always begin each row from the same side of the room. When near a wall, you can use a pry bar to pry close the side and end joints.



INSTALLATION & MAINTENANCE

BEFORE INSTALLING

INSTALLATION

FINISHING

REPLACEMENT

MAINTENANCE

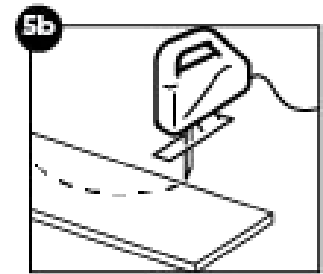
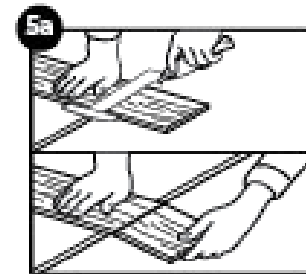
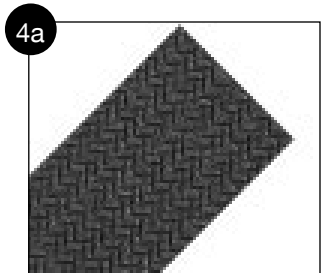
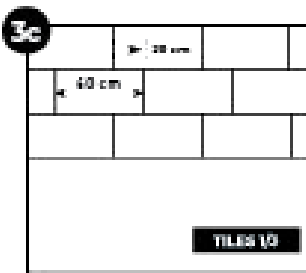
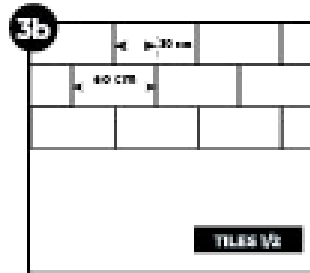
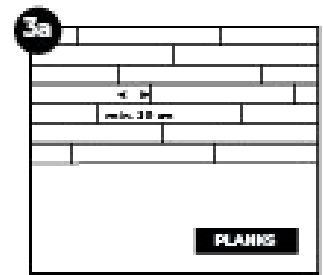
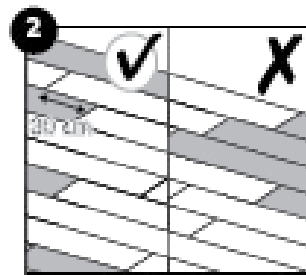
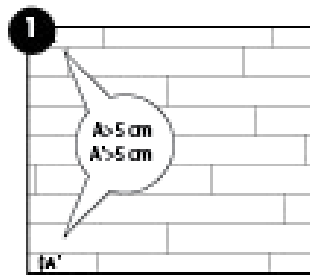

- 1 Before starting, carefully measure the length and the width of the room to plan a precise layout to achieve a balanced appearance of the floor. This is very important when installing typical tile decors. This will also ensure that you won't end up with the last row being too narrow. If the last row will be less than 2", the installation will be easier and better if you reduce the width of the planks of the first row.
- 2 During installation, make sure that you mix the floor panels (and floor boxes) sufficiently so that there are not too many identical, lighter or darker planks next to each other. To obtain the best visual effect, it is best to install the panels in the direction of the longest wall and/or parallel to the incidence of light. Ensure that the end joints of the panels in 2 successive rows are never in line, they should be staggered by at least 30cm for planks and at least 7.8" for tiles. For a natural look and better mechanical strength, we do not recommend an installation of the planks in a pattern but rather at random formation.
- 3 Install rigid vinyl planks randomly: Vertical joints should be staggered in a random pattern with minimum 7.8" over (3a). Install rigid vinyl tiles methodically: Vertical joints should be staggered with half overlap (3b) or one-third overlap (3c).
- 4 Density Ocean View has attached underlayment and there is no need to lay down any additional underlayment. Please make sure to sweep and clean the area before installation.
- 5 To shorten the length of the plank with a straight cut, you can cut the Density Ocean View floors with the decor side face up, using a special concave vinyl cutting knife. In order to cut the vinyl plank, draw a straight line along which you will be cutting, and use the knife to make a firm cut in the surface. You never need to completely cut through the vinyl. Then break off the plank using both hands. For any other cuts, you need to saw the planks. Depending on the type of saw, position your plank with the decor side face-up or face-down. Before making the actual cut, use a leftover piece to determine how the cleanest cut can be obtained (decor side face-up or face-down).

INSTALLATION & MAINTENANCE

BEFORE INSTALLING

INSTALLATION

FINISHING

REPLACEMENT

MAINTENANCE

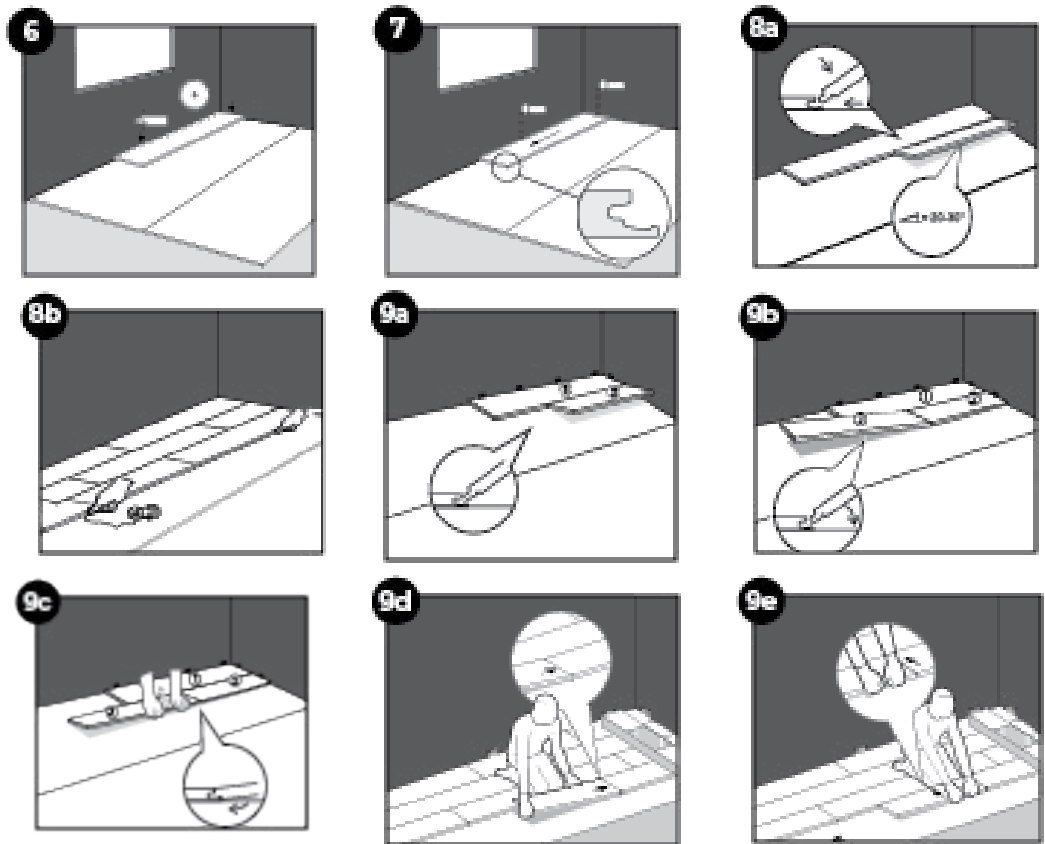

- 6** With Density Ocean View you can choose where you want to start in the room. Think about what will be the easiest way to install the floor. We will demonstrate the installation of Density Ocean View floor for right-handed people, from right to left (from front viewpoint). Because of the Uniclic click system, you can work in either direction.
- 7** Start with the first plank that will be installed in the corner. Remove the click profile on both the long and the short side of the plank by sawing. For other planks of the first row (not in the corner), remove the click profile on the long side that will be directly next to the wall. Any side of a plank that is directly next to a wall, must have its click profile removed, in order to ensure the required expansion gap.
- 8** In order to make the start of the installation easier, assemble the first 3 rows away from the wall, so you can sit on the planks during the assembly. Then slide the first 3 rows at the wanted position close to the wall with distance spacers in place. Take a thin rope and hold it alongside the installed planks to check and adjust the straightness of your installed first 3 rows. It is recommended to make additional checks of the straightness, in order to confirm the straightness during the installation. Remember to use the distance spacers for the expansion gap of 8 mm (0,315 inch) along the perimeter.
- 9** Uniclic® is unique because you can install the planks in two different ways.
Method A (angle-angle): First, rotate the short side of the plank to be installed, into the short side of the already installed plank, by means of the angle principle. Then raise the newly installed plank to an angle of 20-30°. This will also raise the previously installed planks in the same row, because their short sides are already connected.
 Now place your **BOTH** hands close to the joint as shown in the figure and pull the long side of the plank towards you. The panels will now click together. You can either insert the tongue into the groove, or the groove on to the tongue. The tongue in groove method is the most common and easiest way.

INSTALLATION & MAINTENANCE

BEFORE INSTALLING

INSTALLATION

FINISHING

REPLACEMENT

MAINTENANCE

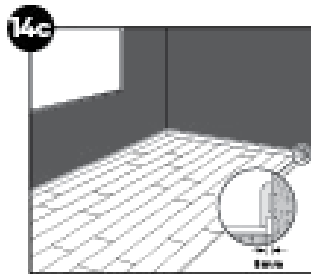
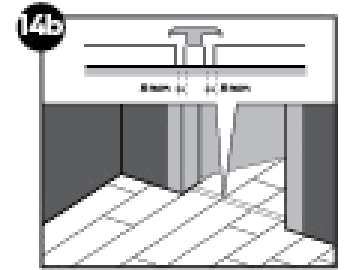
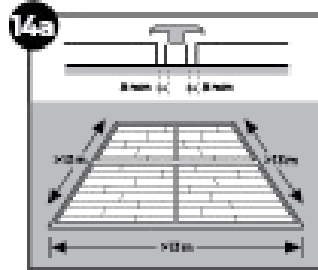
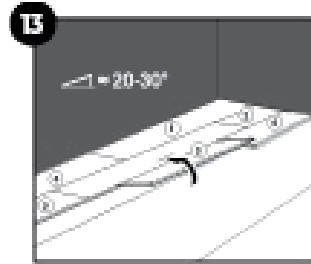
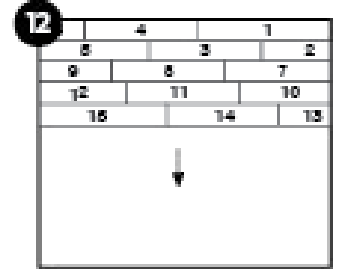
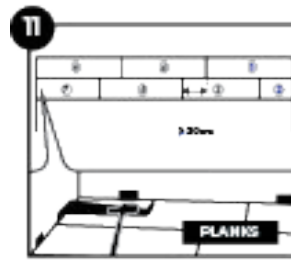
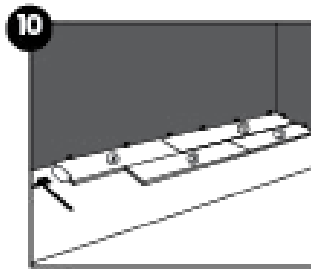

- 10** Method B (taping): With Unilic® you can also join the panels, by tapping the planks into each other, eliminating the need to lift them. This method requires the use of the special Unilic® tapping block. The panels should not be joined with a single tap. To avoid damaging the panels you must tap them together gradually. You can angle the short or long side of the plank first and then tap to connect the other side.
- 11** In places where it is too difficult to install the Unilic® panels with the tapping block (e.g. against the wall), you can pull them together using the pull-bar and a hammer.
- 12** Continue the installation like this - row by row - towards the end of the room. The easiest way to work is to sit on the already installed panels.
- 13** After the installation of each panel and before continuing with the next panel, check each short and long side joint to make sure there are no height differences and no openings.
- 14** Room temperature varies continuously, so it is vital that the floor is able to expand and contract. For this reason, make sure you leave an expansion gap of 8 mm (5/16") on all sides of the floor, around pipes, thresholds and under door frames. Expansion gaps can be finished by means of a skirting that is attached to the walls. It is mandatory to leave an expansion gap between different rooms (e.g. under the door) and use a transition/expansion profile.
- a. For standard residential use Maintain temperatures between 55°F (13°C) and 85°F (29°C).
b. Optimal temperature should be 70°F

Larger rooms require additional expansion gaps and expansion profiles.

INSTALLATION & MAINTENANCE

BEFORE INSTALLING

INSTALLATION

FINISHING

REPLACEMENT

MAINTENANCE

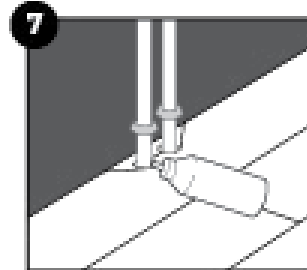
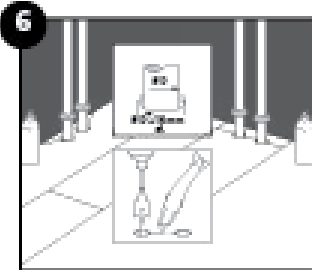
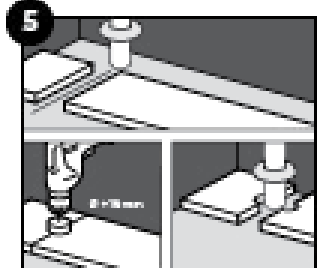
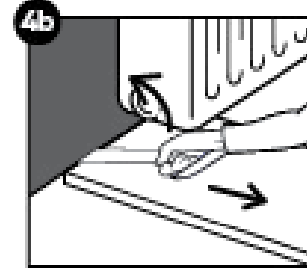
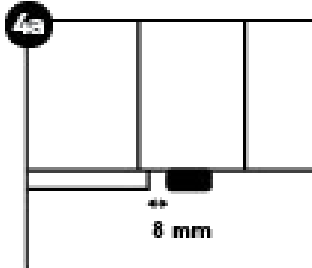
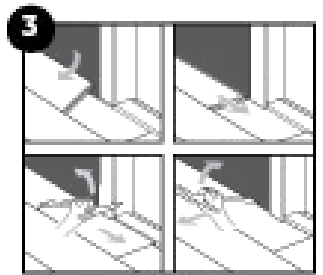
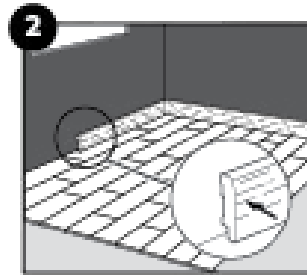
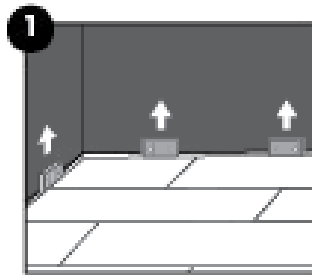

- 1 Remove all spacers.
- 2 Inspect the final surface of the installed floor. Install Density Ocean View vinyl skirtings against the wall but never attach the skirting to the floor itself. This method allows the floor to expand and/or contract under the skirting-board.
- 3 Do not fill or cover the expansion joints with silicone or other kit.
- 4 When the new flooring meets a threshold or a doorway, we recommend undercutting the door frames or moldings. To secure the correct cut, turn a plank upside down with the underlay below, and place it on the floor up to the door frame. This ensures that the cut will be made at the correct height. Then place a hand saw flat against the plank and simply cut through the frame. Remove the cut out piece and vacuum away any debris. Install the plank on the long side, keeping the short side close to the undercut molding. Then slide the plank underneath the undercut towards the already installed plank in order to close the short end joint. Use the Density Ocean View pull bar and/or tapping block to secure absolute tightness in the long and short joint.
- 5 When sawing the panels make sure that the expansion gap under the door is 8mm. If you cannot lift the panel (e.g. under radiators), use the tapping block or pull-bar to tap the planks together.
- 6 In rows where there is a pipe, make sure the pipe falls exactly in line with the short side of two planks. Take a drill bit with the same diameter as the pipe plus 16mm (0,63inch). Click the planks together on the short side and drill a hole centered on the joint between the two planks. Now you can install the planks.
- 7 In case of a double pipe, drill a hole at each of the marked points that is equivalent to the diameter of the pipes plus 16mm. If located on the long side of the plank, make a 45 degree cut from each hole to the edge of the plank.
- 8 Then, using an appropriate PVC glue along the cut edges of the piece you cut out, glue the piece in place. Be sure no glue comes between the cut out piece and the subfloor. For a perfect finish around pipes, use pipe covers.

INSTALLATION & MAINTENANCE

- BEFORE INSTALLING
- INSTALLATION
- FINISHING
- REPLACEMENT**
- MAINTENANCE

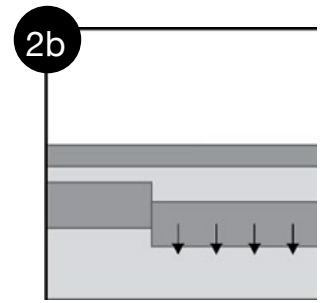
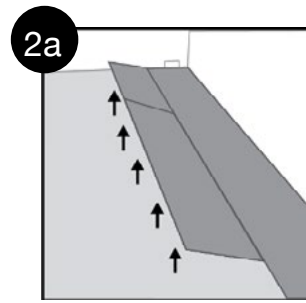
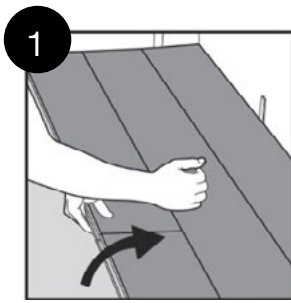

Disassembling Panels Near Walls

- 1 Separate the whole row by carefully lifting up and release the whole row.
- 2a Disassemble the panels by lifting the short ends upward and disengage from the rest.
- 2b Slide one panel forward. Never fold up a panel, as this damage the profile.

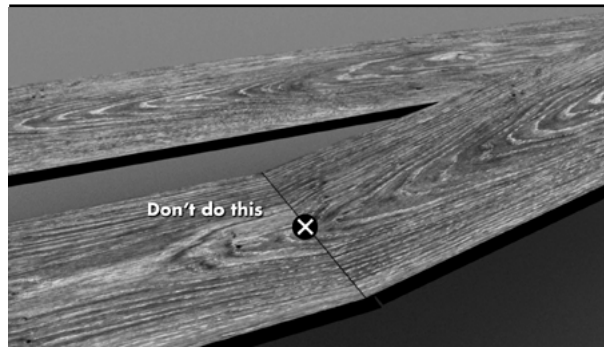

How NOT to Disassemble a Panel

DO NOT lift planks from the center. This will cause damage the groove. Please use the slide method or lift planks from the end joint as shown on the step above.

Replacement of a Panel in the Middle of the Room.

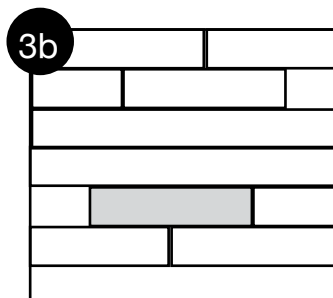
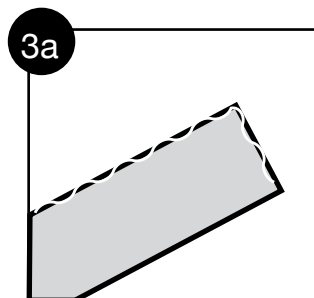
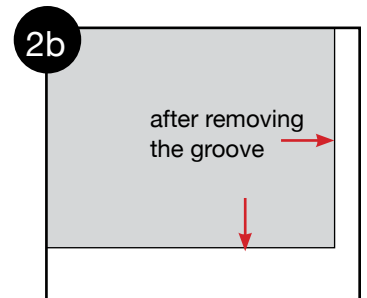
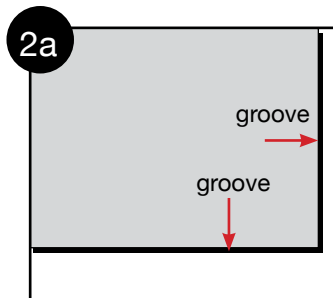
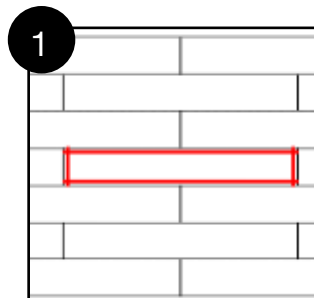

- 1 Please cut the panel along the red lines as indicated below.
- 2a 2b Remove the groove on both sides as indicated in the above pictures.
- 3a 3b Apply glue on the cut groove side to adhere to the adjacent planks.

INSTALLATION & MAINTENANCE

BEFORE INSTALLING

INSTALLATION

FINISHING

REPLACEMENT

MAINTENANCE

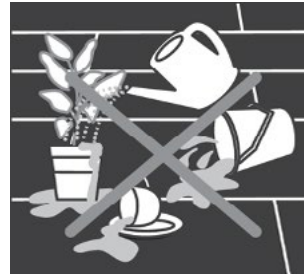
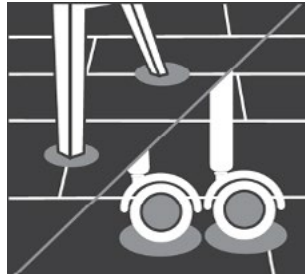

- If the floor experiences expansion/peaking we recommend adhering the planks with an adhesive using fine notch trowel.
- Squeaking noises from the floor are typically caused by lack of expansion around the perimeter or improper subfloor deflection. The lack of expansion will cause the planks to peak on the short ends, therefore, creating tension. The improper subfloor deflection will create movement/tension on the locking system.
- Lasting beauty can be achieved through purchasing a quality floor covering and providing proper on-going maintenance.
- Furniture should be moved onto the newly installed floor using an appliance hand truck over hardboard runways.
- Avoid exposure to long periods of direct sunlight. The floor should not be exposed to direct sunlight for prolonged periods or temperature change to prevent the planks from peaking/bowing. Close blinds or drapes during peak sunlight hours. Floor covering subjected to excessive heat and light is subject to thermal degradation. Use appropriate precautions to minimize potential effects on the floor covering.
- Do not expose floors to temperature exceeding 140° F up to 6 hours.
- Oil or petroleum-based products can result in surface staining. Do not track asphalt-driveway sealer or automobile-oil drips onto the vinyl floor covering.
- Use non-staining mats. Rubber may discolor the floor.
- Caster wheeled chairs should have wide, rubber casters. Protective mats are required under office chairs.
- Frequently moved furniture should be equipped with felt pads to avoid scratching the floor. Heavy furniture and appliances should be equipped with non-staining large surface floor protectors. Furniture with castors or wheels must be easy swiveling, large surface non-staining and suitable for resilient floors. Do NOT use ball type castors as they can damage the floor.
- Use floor protectors under furniture.
- Use walk off mats at entrances to prevent dirt and grit from being tracked on to the floor.
- Sweep or vacuum the floor regularly to remove loose dirt. Do NOT use vacuums that use a beater bar or turn beater bar off.
- Do NOT use electric brooms with hard plastic bottoms with no padding.
- Clean up spills immediately.
- Damp mop as needed using clean water and a diluted floor cleaner. Do NOT use harsh cleaners or chemicals on the floor. DO NOT use abrasive scrubbing tools. Do NOT use detergents, abrasive cleaners or "mop and shine" products.
- Vinyl Flooring, like other types of smooth floors, may become slippery when wet. Allow time for floor to dry after washing.
- Immediately wipe up wet areas from spills, foreign substances or wet feet

Use protective pads under furniture or equipment to reduce risk of surface damage. Please do not use rugs with rubber backing or carpets with vinyl floors

INSTALLATION & MAINTENANCE

BEFORE INSTALLING

INSTALLATION

FINISHING

REPLACEMENT

MAINTENANCE

RESIDENTIAL MAINTENANCE GUIDELINES

Newly Installed Floor Care

- Always use plywood or other boards when moving heavy objects across the floor.
- Sweep, dust mop or vacuum the floor to remove all loose dirt and grit.
- Lightly damp mop with well wrung mop.

Initial & Routine Maintenance (Daily Or As Needed)

- Sweep, dust mop or vacuum the floor to remove all loose dirt and grit. Do not use treated dust mops.
- Clean the floor using a properly diluted Neutral pH cleaner in cool water or ready to use spray cleaner that will not leave a residue such as Bona Professional Series Stone, Tile, and Laminate Cleaner in a pre-mixed spray bottle. Follow label instructions.

Over Time Floor Care

Over time floors may begin to lose their luster and may require an application of floor polish. When and where you apply the floor, polish will depend on the traffic the floor receives. A good quality floor polish like “Hilway Direct” can provide up to a year of protection in a high traffic area.

Floor Polish Application Directions:

1. Vacuum or dry sweep then damp mop floor to remove loose dirt and soil from floor. Thoroughly scrub and clean floor with Neutral pH cleaner to remove all soil. Follow label Instructions.
2. Apply floor polish undiluted in a thin, even coat using a microfiber applicator mop. Do not use treated dust mops. Follow label instructions.
3. Apply 2-3 coats. Allow each coat to air dry completely (generally 30-60 minutes) before applying next coat.
4. Allow floor surface to dry overnight before heavy traffic use.

Prevention

The single greatest cause of damage to any flooring or floor finish is abrasion from dirt and grit. Wherever possible, use walk off mats at entrances and doorways. Use non-staining floor protectors under heavy furniture, chairs, and tables.

COMMERCIAL MAINTENANCE GUIDELINES

Safety Precautions

- When performing any wet maintenance, always put out wet floor signs and caution tape.
- When wet maintenance is finished and the floor is dry, remove all caution signs & tape.
- Carefully read and follow each product’s label instructions for proper use.
- Refer to each product’s MSDS for use of personal protective equipment.

Newly Installed Floor Care

- Always use plywood or other boards when moving heavy objects across the floor.
- Follow the Initial & Routine Maintenance instructions below.

Initial & Routine Maintenance (Daily Or As Needed)

- Sweep, dust mop or vacuum the floor to remove all loose dirt and grit. Do not use treated dust mops.
- Clean the floor using a properly diluted Neutral pH cleaner (Hilway Direct – Neutral Cleaner) in cool water. Follow label instructions.
- Mop or machine clean using 175-rpm “Swing-arm” machine or auto scrubber with a 3M

INSTALLATION & MAINTENANCE

BEFORE INSTALLING

INSTALLATION

FINISHING

REPLACEMENT

MAINTENANCE

5100 Red pad (or equal). If the flooring has painted bevel using a buffing machine can remove the painted bevel.

- Rinse the floor thoroughly with clean water and allow it to dry. Fans or air movers can speed up the drying time.

Daily Cleaning Directions:

- Sweep floor to remove loose dirt & soil.
- Using Mop & Bucket (2-bucket system) or Auto-Scrub Machine, dilute Hilway Direct Neutral Cleaner as directed on product label. Mop floor with the cleaning solution.
- Trail mop excess soil and wet areas with a clean, tightly wrung out mop.
- No rinsing required.
- Allow floor to air dry completely.

Caution: Eye irritant. Avoid contact with skin and eyes. Do not taste or swallow. In case of contact with eyes or skin, flush with plenty of water. If irritation develops, seek medical attention. In case of ingestion, flush mouth with water, drink large quantities of water and seek immediate medical attention, DO NOT induce vomiting.

Keep Out Of Reach Of Children.

Note: Avoid solution contact with sensitive surfaces such as wood, metal, furnishings. When applying finish, avoid strong sunlight and drafts. Turn off under floor heat prior to application. Read full MSDS (available for download: www.hilway.com) and product label prior to use. Handling and Storage: Protect from freezing. Recommended storage temperature: 68°F (20°C). Avoid storing in direct sunlight and high temperatures. Do not store near food.

Periodic Deep Cleaning

- Sweep, dust mop or vacuum the floor to remove loose dirt and grit. Do not use treated dust mops.
- Machine scrub the floor using a properly diluted Neutral pH cleaner (Hilway Direct – Neutral Cleaner or mild Alkaline cleaner (Call 1-877-356-6748 for recommended cleaner) solution in cool water. Use a 3M 5300 Blue pad (or equal). Let solution stand for 5-10 minutes. Do not use a black or brown pad.
- Completely remove the cleaning solution with a wet-dry vacuum or auto scrubber and do not allow the solution to dry on the floor.
- Rinse the floor thoroughly with clean water and allow floor to dry. Fans or air movers can speed up the drying time.

Hilway Direct Floor Finish – Matte Application Directions:

- Dry sweep then damp mop floor to remove loose dirt and soil from floor. Thoroughly clean floor with Hilway Direct Neutral Cleaner or Allsafe Stripper.
- Remove any old site-applied acrylic coating. This usually can be done with Hilway Direct Allsafe Stripper diluted 1:5 or 1:10 with clean water, in an auto scrubber or low rpm swing machine with a red or blue pad or equivalent. Always rinse and neutralize floor with clean water after removing old coating. Do not let stripper solution dry on floor.
- Shake Hilway Direct Floor Finish - Matte vigorously for 30 seconds then let it settle for 5 minutes. Apply undiluted in a thin, even coat using a microfiber applicator mop. Do not use treated dust mops.
- Apply 2-3 coats. Allow each coat to air dry completely (generally 30-60 minutes) before applying next coat.
- Allow floor surface to dry overnight before heavy traffic use.

Application Coverage: Undiluted, single coat: 1500 – 2000 square feet/ 1.33 gallons. Coverage may vary depending on porosity of flooring material.

Where to Buy?

For complete maintenance guidelines for your floor contact your local supplier.